



**INTERNATIONAL JOURNAL OF ENGINEERING SCIENCES & RESEARCH
TECHNOLOGY**

INTERNET OF THINGS (IOT) BASED HOME AUTOMATION SYSTEM

Saurabh Singh^{*1}, Harjeet Matharu² & Dr. Sangeeta Mishra³

^{*1,2}Department of Electronics and Communication, Mumbai University, Thakur College of
Engineering and Technology

³Assistant professor, Department of Electronics and Communication, Mumbai University, Thakur
College of Engineering and Technology

DOI: 10.5281/zenodo.1049436

ABSTRACT

This paper purposes the study of Internet of Things (IOT) based home automation system. Internet of things(IOT) based home automation system can be controlled over mobile devices. This system can perform varied functions to be performed at home. This allows accessibility over internet from any corner in the world. The main focus of this project is to minimize the usage of electricity and reduce human efforts. The Home Automation system (HAS) incorporates various aspects of technologies such as wireless networking, communication over cloud. The data to be analyzed is stored onto the cloud. The user can access multiple appliances over the internet as per their convenience. This is a low cost system. This system can control multiple devices

KEYWORDS: Internet Of Things (Iot), User, System, Home Automation System.

I. INTRODUCTION

The demand for automated systems has widely increased due to advancement of Automation Technology. The rapid increase in the number of users of internet has made Internet a part of life, and Internet of things (IOT) is the latest and emerging internet technology. Internet of things (IOT) is basically the interconnection via the internet of computing devices embedded in everyday objects, enabling them to send and receive data. It is a communication between multiple devices with no or less human intervention. Internet of things (IOT) can minimize human efforts. Internet of Things (IOT) analyzes the data retrieved from the sensors and performs appropriate activities thereby saving human time. The assurance to people about their home activities and securities led to the advancement of Home Automation System. The system will continuously update the system information as well as the user. In sec II Methodolgy is discussed. Furthermore in section III, IV, V and VI Results and Discussions, Significance , Future scope and References are discussed

II. METHODOLOGY
Architecture of proposed model

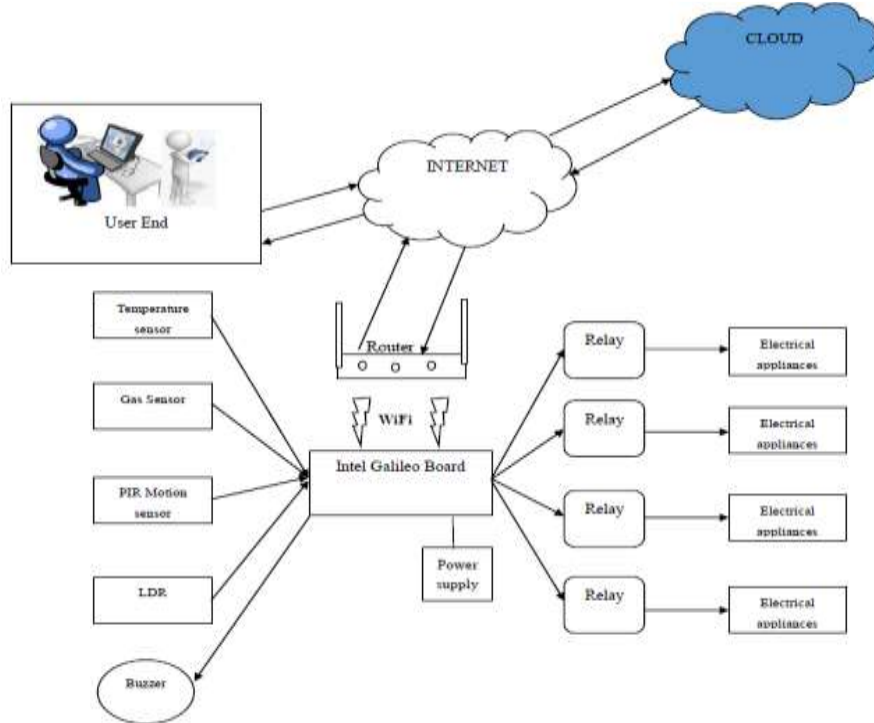

Fig.1: Architecture [1]

ESP8266

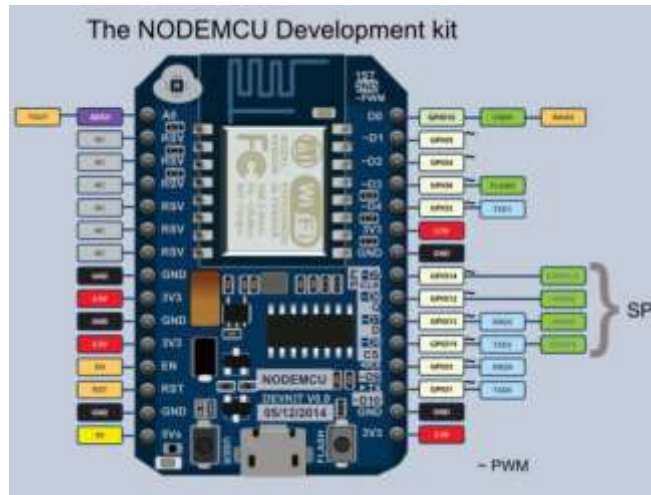

Fig.2: ESP module[3]

The ESP module is an integrated chip which offers a inbuilt strong and high range Wi-fi connectivity. For operating the devices on cloud or over the internet the data is transferred wirelessly to database. Therefore this module provides the most efficient service in its quality. It is a low cost wifi chip.

Wifi Module

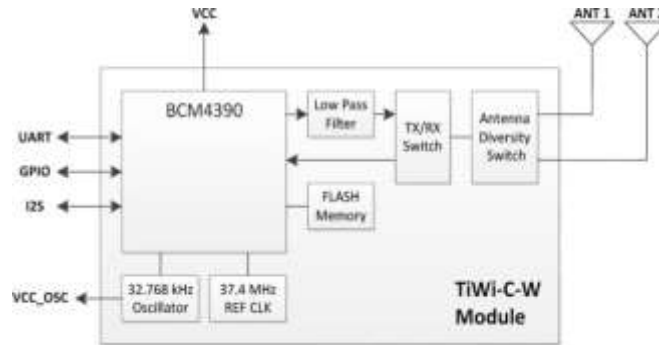

Fig.3: Wifi Module

Wi-fi stands for wireless fidelity. A Wi-fi is very convenient and way more easy to use than a microcontroller. A Wi-fi enabled device is able to send or receive data to the host wirelessly and with ease. Wi-fi is easy and fast way of transferring data. In this project, data is transferred to the cloud using Wi-fi module which is operated by the server. The range of Wi-fi module is very high and it can also penetrate through objects and hence can be placed anywhere in the house. The use of this module in the project will be for transferring the data obtained by the hardware. It sends data to the server and stored into the buffer memory which then is transferred to cloud over Wi-fi and then the operations can be performed on data. [5]

Raspberry pi

The Raspberry Pi is a single board processing unit of very small size. The Raspberry Pi is used as the core processing unit because of its small-size and high usability. The power consumption of raspberry pi is very less. It has a low and affordable cost and hence it is widely used. The GPIO pin configuration is as shown below: [1]



Fig.4: GPIO pin configuration

Voltage Regulator



Fig.5: Voltage Regulator

Voltage regulator is a device which lets the current flow in a regulated way. There are types of voltage regulators namely fixed voltage regulator and variable voltage regulator. The fixed regulator is configured to allow only a particular amount of current while the variable regulator has a range of current which can be passed. Here, in this project a variable voltage regulator is used so that is automatically adjusts itself and

configure to let pass the required amount of current. The amount of current is recorded by a meter and it is stored in the cloud using the Wi-fi module.

Connecting the home Automation Circuit



Fig.6: Home automation kit.

The home automation using IOT project circuit can be connected using various electrical and electronic components, modules, blocks & connecting wires as shown in the above figure.

III. RESULTS AND DISCUSSION

All the information will be transmitted over the cloud to the user. Whenever any unusual activity is noticed the user will be notified by the system. The Raspberry Pi is used as the core processing unit, because of its small size and high usability. The load can be controlled and monitored using a web page or android app with user configurable front end. The user can send commands through the allotted IP and these commands are fed to Wi-Fi module. The Wi-Fi module is configured to access internet using any nearby wireless modem. The commands received by a Wi-Fi module are executed by a program within a Wi-Fi module. The Wi-Fi module interfaced through the loads are turned ON & OFF based on commands. The load status (ON or OFF) will be displayed on the web page and app.

Energy Regulation System

The electricity instead of directly passing to the appliance, is passed through the voltage regulator. The voltage regulator maintains the flow of current and avoids overloading. The controlled flow of current is then passed through a voltage-meter which records the units of voltage used. This data is sent to raspberry pi server and the server stores the data in the database. This data is captured weekly as well as monthly. These statistics are used to calculate the energy consumption bill. An algorithm is used to calculate the energy bill weekly and monthly. The user can set a limit for the units of energy consumed. If the threshold for the unit is reached the user will be notified. The user can switch on/off using as well as regulate the flow of voltage to particular appliances. For example, user can dim the lights, regulate the fan, etc.

Security control system

The user can control every appliance from the application. In case the user isn't at home, she/he can remotely power off the active appliances. This system can be used for security at doors. A CCTV is mounted in front of door. If someone rings the bell and no one is at home, depending on user's choice a picture from the CCTV or a live video feed can be sent to the user via the application or display it on our web app. This control comes handy in situations like – when no one is at home and the child comes back from school and rings the bell. The user will be notified and the digital door can be opened remotely by the user. The door opening mechanism is based on a digital lock which compares a piece of encrypted code sent by the user. This also ensures that even when the cloud or the database is compromised the security code is visible or understandable by the hacker. Also the code from the client (user) side is double encrypted so that it cannot be tapped by a middle man.

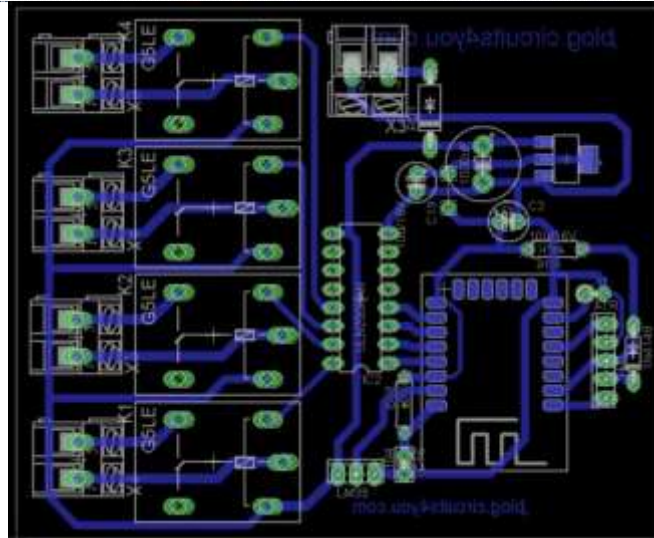

Fig.7: PCB layout of Home automation [1]

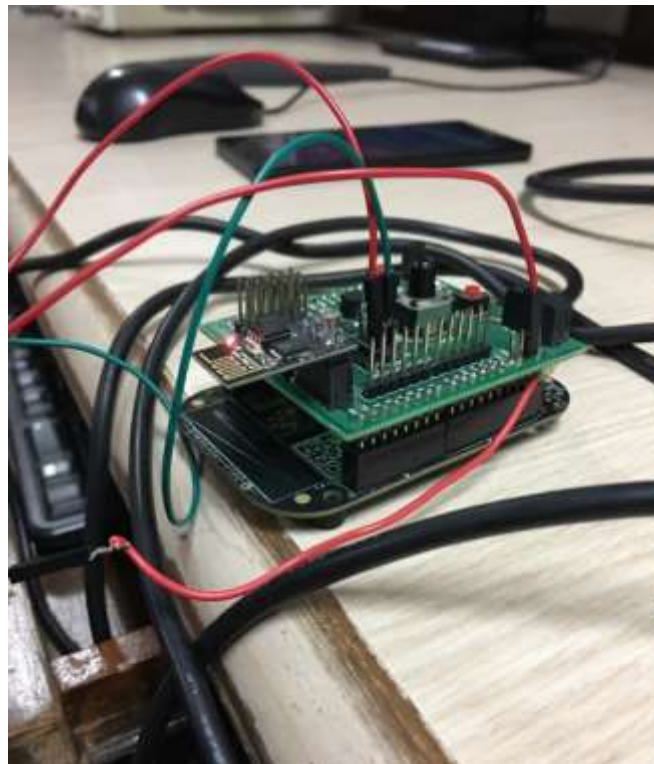

Fig.8: Connection to transfer data to server.

IV. SIGNIFICANCE

User Convenience

The basic advantage is user convenience. It becomes very easy to perform all activities. Even if you are not present at home you can access all your home system remotely. It allows one to keep a track of all the activities taking place at his/her place even in their absence.

Maintaining and Saving energy

This project helps you to manage energy consumption at your place and also provides the benefit of saving energy. For example, it will automate your thermostat to adjust settings throughout the day based on the timing depending on whether someone is at home or not. Some smart devices can be synced up to your appliances with



real-time energy information. This helps your home appliances know the most cost-effective voltage operate.

Enhanced Security

Security is always a important factor which should always be taken in to consideration. With the help of security cameras we can ensure safety of our place and eliminate the presence of unwanted people at our place. We can keep track of all the activities which take place in our home in our absence. Home Automation Systems have many security benefits. It will allow the users to track the activities at their home from any location. Some complete home automation systems will alert the user through phone, text or email if there is any unusual activity at their place. For example, automated systems include automatic door locks and using this system ,the doors can be locked effectively allowing the user to keep a track over it. The fact that the user can be alerted each time someone enters his/her home also allows user to monitor and keep a track of people who is entering his/her place even in their absence.

Environment and Economical contribution

Home automation system allow you to ensure that you are only using the energy and resources that are necessary while you are home, and you are sustaining resources. Home Automation Systems provide convenience and saves your time and effort performing home activities. When you properly manage your energy, you can reduce your energy consumption, which may help you save money.

Parental Control

Parents can have complete control over their children's rooms. For example, its 10pm and if you want your kids to sleep, so just turn off the TV set and lights using your handset. Even if children tries to switch it on again, you'll be notified about the same. So home automation system allows you to keep a track over your children's activity and manage it accordingly

V. FUTURE SCOPE

Home automation has vast scope. Using this system as framework, the system can be expanded to include various other options which could include home security feature like capturing the photo of a person moving around the house and storing it onto the cloud. This will reduce the data storage than using the CCTV camera which will record all the time and stores it. The system can be expanded for energy monitoring, or weather stations. This kind of a system with respective changes can be implemented in the hospitals for disable people or in industries where human invasion is impossible or dangerous, and it can also be implemented for environmental monitoring.

VI. REFERENCES

- [1] Ravi Kishore Kodali, Vishal Jain, Suvadeep Bose and Lakshmi Boppana, "IoT Based Smart Security and Home Automation System", Computing, Communication and Automation (ICCCA), 2016 International Conference on pp. 1286 – 1289, April 2016.
- [2] VinaySagar K and Kusuma S, "Home Automation Using Internet of Things", International Research Journal of Engineering and Technology, Volume 2, Issue 3 on pp. 1965 – 1970, June 2015.
- [3] Stefan Matlak, RazvanBogdan, "Reducing Energy Consumption in Home Automation based on STM32F407 Microcontroller", IEEE, November 2016.
- [4] Su ZinZin Win, Zaw Min MinHtun, HlaMyoTun, "Smart Security System For Home Appliances Control Based On Internet Of Things" IJSTR, Volume-5, Issue 6, June 2016.

CITE AN ARTICLE

Singh, S., Matharu, H., & Mishra, S., Dr. (n.d.). INTERNET OF THINGS (IOT) BASED HOME AUTOMATION SYSTEM. INTERNATIONAL JOURNAL OF ENGINEERING SCIENCES & RESEARCH TECHNOLOGY, 6(11), 239-244.